

# FMV 130E

## FIRŠT MIXING VALVES

3-way rotary brass valves for mixing or diverting applications

FIRST®

### EURONORM AXLE SYSTEM



FMV 131E

FMV 132E

FMV 133E

Valves are available in DN 15 – DN 50, with internal, external threads or compression fittings and are rated PN10.

- FIRŠT rotary mixing valves are designed for use: within commercial & domestic heating systems e.g. radiator, underfloor, radiant panel, mixing circuits, plant room, heat pumps, HVAC systems and in solar heating systems...
- Three types of connections are available: internal threads (FMV 131E), external thread (FMV 132E) and compression fittings (FMV 133E)..

### OPERATION

The FIRŠT FMV 131E, 132E and 133E are compact brass valves for use in small and medium sized heating and cooling installations.

Mixing valves are suitable for long-lasting operation because of special sealing construction. Small rotation torque of the valve minimizes valve blocking.

Valves can be additionally equipped with actuators of UNI series.

### MAINTENANCE

Valves require no maintenance. The installation of suitable strainer is recommended.

### INSTALLATION POSITIONS

The valve can be turned and rotated to fit different mounting positions. Valves are designed for use in mixing or diverting applications.

### CHANGEOVER APPLICATION

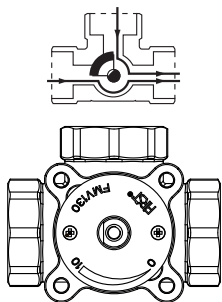

### DIVERTING APPLICATION

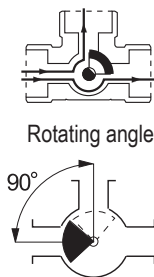

### EURONORM AXLE SYSTEM

Valve allows easy installation of actuators or upgrading valves with actuator. Euronorm axle is standard for most world manufacturers of valves and it is suitable for long-term operation at high torque.



### TECHNICAL DATA

Pressure class:	PN 10
Medium:	water, glycol < 50% water quality as per VDI 2035
Media temperature:	min. -10°C max. +110°C
Leakage ( $\Delta p=1$ bar):	max. 0,5% Kvs
Max. diff. pressure:	1 bar
Connections:	Rp internal thread (EN 10226-1) G external thread (ISO 228-1) compression fittings (EN 1254-2)

### Material

Valve body:	Brass, CW617N
Shaft and rotor:	Brass, CW617N
Bushing:	PTFE
O-Rings:	EPDM,FKM

PED 97/ 23/ EC art 3.3

### FLOW DIAGRAM

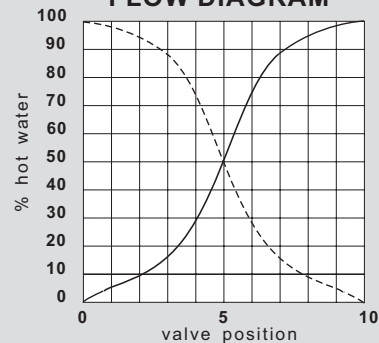

### SUITABLE ACTUATORS



- UNI 3P
- UNI 2P
- UNI MOD X
- UNI TEMP

FIRST®

FIRŠT d.o.o.  
Koroška cesta 56  
SI-3320 Velenje  
SLOVENIA

phone: +386 3 898 35 00  
fax: +386 3 898 35 35  
email: info@first.si  
web: www.first.si

www.first.si  
Let Firšt be your first choice.



# FMV 130E

## FIRŠT MIXING VALVES

3-way rotary brass valves for mixing or diverting applications

### FMV 131E

internal threads

### FMV 132E

external threads

### FMV 133E

compression fittings

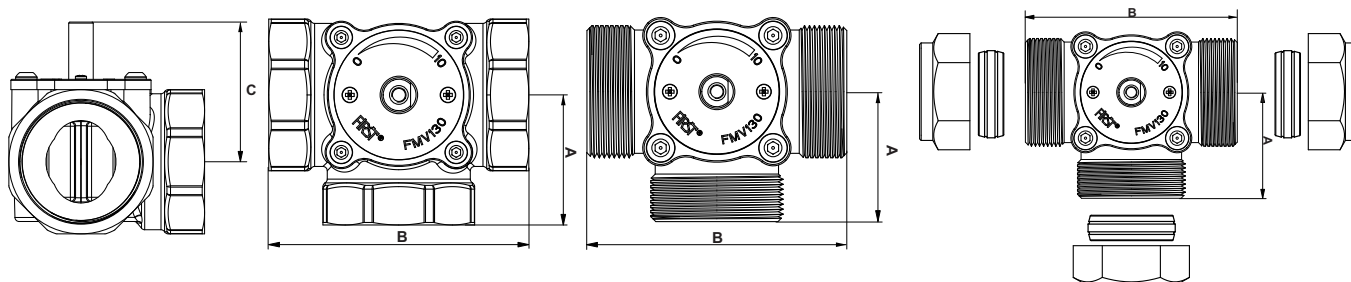

#### FMV 131E, internal threads

Code	Type	DN	Kvs	Connection	A	B	C	Weight [kg]	Price (€)
42012	FMV131E DN15 Rp 1/2" FFF	15	4	Rp 1/2"	36	72	56	0,48	
42013	FMV131E DN20 Rp 3/4" FFF	20	6,3	Rp 3/4"	36	72	56	0,55	
42014	FMV131E DN25 Rp 1" FFF	25	10	Rp 1"	41	82	56	0,64	
42015	FMV131E DN32 Rp 1 1/4" FFF	32	15	Rp 1 1/4"	47	94	59	1,0	
42016	FMV131E DN40 Rp 1 1/2" FFF	40	25	Rp 1 1/2"	53	106	66	1,6	
42017	FMV131E DN50 Rp 2" FFF	50	40	Rp 2"	60	120	68	2,3	

#### FMV 132E, external threads

Code	Type	DN	Kvs	Connection	A	B	C	Weight [kg]	Price (€)
42018	FMV131E DN15 G 3/4" MMM	15	4	G 3/4"	36	72	56	0,48	
42019	FMV131E DN20 G 1" MMM	20	6,3	G 1"	36	72	56	0,55	
42020	FMV131E DN25 G 1 1/2" MMM	25	10	G 1 1/2"	41	82	56	0,64	
42021	FMV131E DN32 G 1 1/4" MMM	32	15	G 1 1/4"	47	94	59	1,0	

#### FMV 133E, compression fittings

Code	Type	DN	Kvs	Connection	A	B	C	Weight [kg]	Price (€)
42022	FMV133E DN20 C22mm CCC	20	6,3	CPF 22 mm	36	72	56	0,55	
42023	FMV133E DN25 C28mm CCC	25	10	CPF 28 mm	41	82	56	0,70	

#### INSTALLATION EXAMPLES

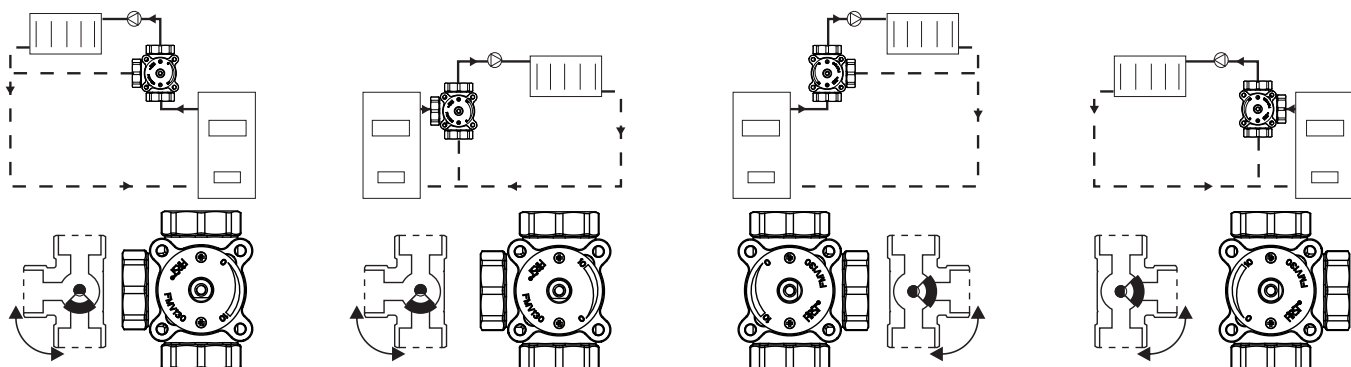

**FIRST**®

**FIRŠT d.o.o.**  
Koroška cesta 56  
SI-3320 Velenje  
SLOVENIA

phone: +386 3 898 35 00  
fax: +386 3 898 35 35  
email: info@first.si  
web: www.first.si

**www.first.si**  
Let First be your first choice.

